



**NSCM: D2356**

**Mode S Transponder Level 2es**

**BXP 6401-1-(XX) Class 1**

**BXP 6401-2-(XX) Class 2**

## **INSTALLATION AND OPERATION**

Manual DV 69801.03 PN 0584.053-071

**Becker Flugfunkwerk GmbH • Baden-Airpark B 108 • 77836 Rheinmünster • Germany**

**Telephone +49 (0) 7229 / 305-0 • Fax +49 (0) 7229 / 305-217**

**<http://www.becker-avionics.de> • e-mail: [info@becker-avionics.de](mailto:info@becker-avionics.de) or [support@becker-avionics.de](mailto:support@becker-avionics.de)**

Initial Issue:  
December 2005

**34-50-08** April 2008



**BECKER**  
 AVIONIC SYSTEMS  
 INSTALLATION AND OPERATION  
 BXP 6401-X-(XX)

RECORD OF REVISIONS

REV. NO.	ISSUE DATE	INSERTED		REV. NO.	ISSUE DATE	INSERTED	
		DATE	BY			DATE	BY
1	February 2007	02/07	Becker				
2	April 2007	04/08	Becker				

**BECKER**  
AVIONIC SYSTEMS  
INSTALLATION AND OPERATION  
BXP 6401-X-(XX)

BLANK

**BECKER**  
 AVIONIC SYSTEMS  
 INSTALLATION AND OPERATION  
 BXP 6401-X-(XX)

LIST OF EFFECTIVE PAGES

<u>SUBJECT</u>	<u>PAGE</u>	<u>DATE</u>	<u>SUBJECT</u>	<u>PAGE</u>	<u>DATE</u>
Title Page	TP-1	April 2008		3-7	Dec. 2005
	TP-2			3-8	Dec. 2005
				3-9	Dec. 2005
Record of Revisions	ROR-1	April 2008		3-10	Dec. 2005
	ROR-2	Dec. 2005			
List of Effective Pages	LEP-1	April 2008			
	LEP-2	Dec. 2005			
Introduction	Intro-1	April 2008			
	Intro-2	April 2008			
	Intro-3	April 2008			
	Intro-4	Dec. 2005			
Table of Contents	I-I	Dec. 2005			
	I-II	Dec. 2005			
General Description	1-1	Feb. 2007			
	1-2	April 2008			
	1-3	April 2008			
	1-4	Dec. 2005			
	1-5	Dec. 2005			
	1-6	April 2008			
	1-7	April 2008			
	1-8	Dec. 2005			
Table of Contents	II-I	Dec. 2005			
	II-II	Dec. 2005			
Installation	2-1	Feb. 2007			
	2-2	Dec. 2005			
	2-3	Feb. 2007			
	2-4	Dec. 2005			
	2-5	April 2008			
	2-6	Feb. 2007			
	2-7	Dec. 2005			
	2-8	Dec. 2005			
	2-9	Dec. 2005			
	2-10	April 2008			
	2-11	Dec. 2005			
	2-12	Dec. 2005			
Table of Contents	III-I	Dec. 2005			
	III-II	Dec. 2005			
Operation	3-1	Dec. 2005			
	3-2	Dec. 2005			
	3-3	Dec. 2005			
	3-4	Dec. 2005			
	3-5	Dec. 2005			
	3-6	Dec. 2005			

**BECKER**  
AVIONIC SYSTEMS  
INSTALLATION AND OPERATION  
BXP 6401-X-(XX)

BLANK

**BECKER**  
AVIONIC SYSTEMS  
INSTALLATION AND OPERATION  
BXP 6401-X-(XX)  
INTRODUCTION

1. General

The single block Mode S transponder BXP 6401-X-(XX) is described in this manual "Installation and Operation".

2. Manufacturer

The Mode S transponder was developed and is manufactured by :

Becker Flugfunkwerk GmbH  
Baden-Airpark B 108  
77836 Rheinmünster / Germany

Telephone: +49 (0) 7229 / 305-0  
Telefax: +49 (0) 7229 / 305-217  
<http://www.becker-avionics.de>  
e-mail: [info@becker-avionics.de](mailto:info@becker-avionics.de) or [support@becker-avionics.de](mailto:support@becker-avionics.de)

CERTIFIED QUALITY SYSTEM

The Becker quality management system is certified according to :

DIN EN ISO 9001:2000 CERT Reg. - Nr. 12 100 20985

LICENSES AND APPROVALS

DE.21G.0075	Approval as manufacturer to EASA PART 21
DE.145.0166	Approval as maintenance organization to EASA PART 145

3. Safety information

- The installation of the Mode S transponder into an aircraft may be carried out only by an authorized installation company. The country regulations always have to be observed.
- Do not connect the unit to AC sources.
- Make sure that the unit is connected to a DC source  $\leq 33$  V DC.
- If no load is connected to pin 6 of P9, the unit should be protected from the aircraft power supply by a dedicated 3A circuit breaker.
- If an external load is connected to pin 6 of P9, the circuit breaker should be a 5A type.
- Do not connect the unit with reversed polarity to the DC source.
- Do not switch on the unit before the aircraft engines are started. Switch off the unit before the engines are shut down.

**BECKER**  
AVIONIC SYSTEMS  
INSTALLATION AND OPERATION  
BXP 6401-X-(XX)

- Do not operate the unit under ambient temperatures below -20° C and above + 70° C.
- Voltages > 42 V are possible within the transponder.
- The programming of the address module AM 6400-1 with the ICAO 24-bit address of the aircraft must be carried out only at an installation company or in the manufacturer factory.

4. Layout of manual

The manual is divided into three chapters:

- GENERAL DESCRIPTION
- INSTALLATION
- OPERATION

5. Revisions of the manual

All changes to the manual are recorded consecutively on the pre-page "Record of Revisions".

6. List of abbreviations

AA	Aircraft Address (24-bit ICAO)
ADLP	Avionics Data Link Processor
AI	Aircraft Identifier
ALT	Altitude or transponder ALT mode
ATC	Air Traffic Control
BIT	Built-In Test
CBIT	Continuous Built-In Test
CCS	Company Call Sign
CS	Call Sign
DV	Manual identification number
EASA	European Aviation Safety Agency
ELS	Elementary Surveillance
EHS	Enhanced Surveillance
es	e = Extended squitter and s = SI capability
FAA	Federal Aviation Administration
FL	Flight Level
FMS	Flight Management System
FN	Flight Number
GICB	Ground Initiated Comm-B
GND	Ground
ICAO	International Civil Aviation Organization
IBIT	Initiated Built-In Test
ID	Identifier
IDT	Ident (Identification)
IFR	Instrument Flight Rules



**BECKER**  
AVIONIC SYSTEMS  
INSTALLATION AND OPERATION  
BXP 6401-X-(XX)

MTL	Minimum Triggering Level
ON	Transponder ON mode (without altitude transmission)
NSCM	Nato Supply Code of Manufacturers
PBIT	Power-on Built-In Test
PN	Part Number
R	Reply
RX	Receiver
SBY	Standby mode
SEL	Selection
SI	Surveillance Identifier
SPI	Special Position Identification Pulse
STO	Store
SUPP	Supply voltage DC
TCAS	Traffic Alert and Collision Avoidance System (US)
TIS	Traffic Information Service
TN	Tail Number
TX	Transmitter
VFR	Visual Flight Rules
XPDR	Transponder

**BECKER**  
AVIONIC SYSTEMS  
INSTALLATION AND OPERATION  
BXP 6401-X-(XX)

BLANK

**BECKER**  
AVIONIC SYSTEMS  
INSTALLATION AND OPERATION  
BXP 6401-X-(XX)

TABLE OF CONTENTS

GENERAL DESCRIPTION		Page
1.	Application	1-1
2.	General description	1-1
3.	Technical data	1-2
4.	Software	1-6
5.	System approvals	1-6
6.	Equipment	1-6
7.	Accessories	1-6

**BECKER**  
AVIONIC SYSTEMS  
INSTALLATION AND OPERATION  
BXP 6401-X-(XX)

BLANK

**BECKER**  
AVIONIC SYSTEMS  
INSTALLATION AND OPERATION  
BXP 6401-X-(XX)

GENERAL DESCRIPTION

1. Application

The single block Mode S transponder BXP 6401-X-(XX) is the airborne component of the Air Traffic Control (ATC). It functions in accordance with the secondary radar principle and allows air traffic control to locate, identify and track aircraft.

2. General description

- A. The BXP 6401-X-(XX) transponder is designed as a single block unit and is intended for installation in the instrument panel of aircraft. The dimensions correspond to the standard instrument size with a 58 mm (2¼ inch) diameter.
- B. All control elements are located on the front panel of the unit. The two 25-pin unit connectors for connection to the aircraft interwiring, the 5-pin subminiature connector for the Address Module AM 6400-1-(XX) and the TNC antenna socket are located at the rear side of the unit.
- C. Serial interfaces RS-422 are available at the unit connectors.
- D. The Mode S transponder provides the following features:
- (1) In the selective mode (Mode S), the Ground Control can interrogate the transponder individually using an ICAO-24-bit address, which is unique to the particular aircraft.
  - (2) Support of the SI code (Surveillance Identifier)
  - (3) Register capability for elementary surveillance (ELS) and enhanced surveillance (EHS)
  - (4) Extended squitters transmission
  - (5) Data link capability
- E. Inherent features:
- (1) Mode A - in this mode, the 4096 character code set on the control head is sent as a reply to interrogation from a ground station.
  - (2) Mode C - in this mode, the encoded altitude is sent in addition to the mode A reply. The altitude information must be delivered from an external device (e.g. Becker Blind Encoder BE6400).
  - (3) A special identifier pulse (SPI) can be activated by pressing the IDT button in Mode A/C and Mode S.
  - (4) Selftests (BITs). The Initiated Built-In Test (IBIT), the Continuous Built-In Test (CBIT) and the Power-on Built-In Test (PBIT) are integrated in the transponder.

**BECKER**  
 AVIONIC SYSTEMS  
 INSTALLATION AND OPERATION  
 BXP 6401-X-(XX)

3. Technical data

A. General data

Supply voltage	10.0 V to 33.0 V DC
Typical consumption	50 mode S replies/sec. + Squitter 0.37 A at 14 V (illumination off) 0.22 A at 28 V (illumination off) 0.43 A at 14 V (illumination max.) 0.25 A at 28 V (illumination max.) in standby mode: 0.22 A at 14 V (illumination off) 0.14 A at 28 V (illumination off) 0.28 A at 14 V (illumination max.) 0.16 A at 28 V (illumination max.)
Panel illumination	control input
Illumination control current	max. 1 mA at 28V
Illumination color (display and buttons)	white
Serial interfaces	RS-422
Data link capability	255 GICB registers
DME suppression:	
- input voltage	< 2 V (no suppression) > 8 V (suppression)
- output voltage	< 0.5 V (not active) > 18 V (active)
External Ident input:	
“0” (active)	≤ 3.5 V
“1” (passive)	≥ 4.0 V
I <sub>source</sub> (shorted to GND)	≤ 10 mA
Ground detection input:	
“ground”	≤ 0.5 V
“airborne”	≥ 2 V
I <sub>source</sub> (shorted to GND)	≤ 10 mA
Power-up time	2 s (including internal self-test)
Internal fuse protection	F 5 A
External fuse protection	T 3 A (circuit breaker) *
Operating temperature range	- 20° C to + 55° C (short-time + 70° C)
Storage temperature range	- 55° C to + 85° C

\* NOTE:

5 A circuit breaker if an external load is connected to pin 6 at P9.

**BECKER**  
 AVIONIC SYSTEMS  
 INSTALLATION AND OPERATION  
 BXP 6401-X-(XX)

Operating altitude	50000 ft. max. (class 1) 15000 ft. max. (class 2)
Mode S	Class 1 or 2, Level 2es - extended squitter capability - surveillance identifier (SI code)
Conformity	RTCA DO-181C, FAA TSO-C112, class 2A or 2B, Eurocae ED-73B, Level 2es, EASA ETSO-2C112a, class 1or 2
Environmental conditions (see also paragraph D)	in accordance with EUROCAE/ RTCA ED-14D/DO-160D
Mechanical dimensions :	
- Front panel	61.3 x 61.3 mm (H x W) (2.413 x 2.413 inch)
- Instrument size diameter	58 mm (2¼ inch)
- Case depth	
	without antenna socket 192 mm (7.599 inch) with antenna socket 206 mm (8.110 inch) with address module 239 mm (9.409 inch)
Weight	approx. 0.8 kg (1.764 lb)
 B. Receiver data	
Operating modes	Mode A/C/S, depending on interrogation
Receive frequency	1030 MHz ± 0.1 MHz (mode A/C) 1030 MHz ± 0.01 MHz (mode S)
Sensitivity (MTL)	- 74 dBm ± 3 dB (for 90 % reply rate in mode A/C and 99 % in mode S)
Selectivity	± 15 MHz > 40 dB ± 25 MHz > 60 dB
Dynamic range	≥ 60 dB
Bandwidth	± 3 MHz < 3 dB
Modulation (mode A/C)	PAM (Pulse Amplitude Modulation)
Modulation (mode S)	DPSK (Differential Phase Shift Keying)
Side lobe suppression	3-pulse method (mode A/C) P5 (mode S)
Nominal impedance	50 Ω

**BECKER**  
 AVIONIC SYSTEMS  
 INSTALLATION AND OPERATION  
 BXP 6401-X-(XX)

C. Transmitter data

Transmit frequency	1090 MHz $\pm$ 1 MHz
Transmit modulation	12MOM1D PAM (Pulse Amplitude Modulation)
Transmitter type	Solid state
Transmit power (class 1)	$\geq$ 125 W (+ 21 dBW) at antenna end terminal and $\geq$ 250 W at unit output
Transmit power (class 2)	$\geq$ 70 W (+ 18.5 dBW) at antenna end terminal and $\geq$ 140 W at unit output
Reply rate capability (mode A/C)	at least 1200 mode A/C replies per second for a 15 pulse coded reply, can be limited to 500...1200
Reply rate capability (mode S)	at least 50 mode S replies in one-second interval (thereof at least 16 long formats)
Mode S squitter rate (approx.)	Acquisition squitter 4/sec. Extended squitter 1/sec.
Reply code (mode A)	ICAO coding system with 4096 pulse reply possibilities (octal code)
Altitude code (mode C)	ICAO coding system 100 ft. steps from -1000 to 62700 ft.
Altitude code (mode S)	25 ft. or 100 ft. steps (depending on source)
Transmit pulse shape	pulse width $0.45\mu\text{s} \pm 0.1\mu\text{s}$ (mode A/C) pulse width $0.5\mu\text{s} \pm 0.05\mu\text{s}$ (mode S) rise time 0.05 to 0.1 $\mu\text{s}$ fall time 0.05 to 0.2 $\mu\text{s}$
Nominal output impedance	50 $\Omega$

D. Environmental conditions in accordance with EUROCAE/RTCA ED-14D/DO-160D

Input voltage range	10.0 to 33.0 V DC
Low operating temperature	-20°C
High operating temperature	+ 55°C
High short-time operating temperature	+ 70°C
Storage temperature range	- 55°C to + 85°C
In-flight loss of cooling	Cat. Z, no auxiliary cooling required



**BECKER**  
 AVIONIC SYSTEMS  
 INSTALLATION AND OPERATION  
 BXP 6401-X-(XX)

Altitude	50000 ft. max. (class 1) 15000 ft. max. (class 2)
Humidity	Cat. A / + 50°C; 95%, 48 h
Vibration resistance	Cat. S, test curve M Cat, U, test curve G
Operational shocks	6 g in any direction
Crash safety	20 g shocks 20 g acceleration
Magnetic effect	Category Z

Environmental categories:

Env.Cat. [D1Z]BAB[(SM)(UG)]XXXXXXZBABA[WW]B[A3E3X]XXA

E. Environmental qualification

EUROCAE/RTCA ED-14D/DO-160D

Condition	Section	Cat.	Description
Temperature and Altitude	4.0	D1	Equipment tested to Category D1
Low Ground Survival Temperature	4.5.1	D1	-55 deg C
Low Operating Temperature	4.5.1	D1	BXP 6401-X-(XX): -20 deg C,
High Ground Survival Temp	4.5.2	D1	+85 deg C
High Short-Time Operating Temp.	4.5.2	D1	+70 deg C
High Operating Temp.	4.5.2	D1	+55 deg C
In-flight Loss of Cooling	4.5.4	Z	No forced cooling required – No test required
Altitude	4.6.1	D1 A1	BXP 6401-1-(XX): 50000 ft (class 1) BXP 6401-2-(XX): 15000 ft (class 2)
Decompression	4.6.2		Not applicable
Overpressure	4.6.3		Not applicable
Temperature Variation	5.0	B	Equipment tested to Category B
Humidity	6.0	A	Equipment tested to Category A
Shock and Crash Safety	7.0	B	Equipment tested to Category B
Vibration	8.0	S U	Cat. S, vibration test curve M Cat. U, vibration test curve G
Explosion Proofness	9.0	X	No test required, Equipment identified as Category X
Waterproofness	10.0	X	No test required, Equipment identified as Category X
Fluids Susceptibility	11.0	X	No test required, Equipment identified as Category X
Sand and Dust	12.0	X	No test required, Equipment identified as Category X
Fungus Resistance	13.0	X	No test required, Equipment identified as Category X
Salt Spray	14.0	X	No test required, Equipment identified as Category X
Magnetic Effect	15.0	Z	Equipment is Class Z
Power Input	16.0	B	Equipment tested to Category B
Voltage Spike	17.0	A	Equipment tested to Category A
Audio Freq. Conducted Susceptibility	18.0	B	Equipment tested to Category B
Induced Signal Susceptibility	19.0	A	Equipment tested to Category A

**BECKER**  
 AVIONIC SYSTEMS  
 INSTALLATION AND OPERATION  
 BXP 6401-X-(XX)

Condition	Section	Cat.	Description
Radio Frequency Susceptibility	20.0	WW	Equipment tested to Category WW
Spurious RF Emission	21.0	B	Equipment tested to Category B
Lightning Induced Transients Susceptibility	22.0	A3E3X	Equipment tested to Category A3E3X
Lightning Direct Effects	23.0	X	No test required, Equipment identified as Category X
Icing	24.0	X	No test required, Equipment identified as Category X
Electrostatic Discharge	25.0	A	Equipment tested to Category A

4. Software

The transponder BXP 6401-X-(XX) is controlled by a microcontroller in the control head and the core unit. The software criticality is determined to be **Level C** in accordance with EUROCAE/RTCA document ED12B/DO-178B.

5. System approvals

EASA.210.322	ETSO-2C112a
FAA	TSO-C112

6. Equipment

BXP 6401-1-(01)	Transponder, Level 2, class 1	Article-No. 0588.687-915
BXP 6401-2-(01)	Transponder, Level 2, class 2	Article-No. 0588.709-915
AM 6400-1-(01)	Address Module	Article-No. 0572.942-915
BE6400-01-(01)	Blind Encoder	Article-No. 0592.137-915

7. Accessories

AMP 6400-1	Address Module programmer kit (software and cable), parallel interface	Article-No. 0584.843-954
AMP 6400-2	Address Module programmer kit (software, adapter and cable), USB interface	Article-No. 0604.054-954
CK 4401-C	Standard connector kit 1 D-Sub plug, 25-pin (crimp version)	Article-No. 0552.798-954
CK 4401-S	Standard connector kit 1 D-Sub plug, 25-pin (soldering version)	Article-No. 0552.801-954

**BECKER**  
AVIONIC SYSTEMS  
INSTALLATION AND OPERATION  
BXP 6401-X-(XX)

CK 6400-C	Extended connector kit 1 D-Sub plug, 25-pin 1 D-Sub jack, 25-pin (crimp version)	Article-No. 0586.064-954
CK 6400-S	Extended connector kit 1 D-Sub plug, 25-pin 1 D-Sub jack, 25-pin (soldering version)	Article-No. 0586.072-954
TNC coaxial connector for RG-58C/U (crimp version)		Article-No. 0551.694-277
TNC coaxial connector for RG-223/U (crimp version)		Article-No. 0551.732-277
TNC coaxial connector for RG-58C/U and RG-223/U (soldering version) or spare connector		Article-No. 0552.781-277 Article-No. 0725.900-277
1A032	Transponder rod antenna	Article-No. 0707.007-952
<u>Coaxial connectors for antenna 1A032:</u>		
BNC antenna connector for RG-58C/U (crimp)		Article-No. 0551.708-277
BNC antenna connector for RG-223/U (crimp)		Article-No. 0551.740-277
BNC antenna connector for RG-58C/U and RG-223/U (soldering)		Article-No. 0552.771-277
<u>Manuals:</u>		
Installation and Operation BXP 6401-X-(XX)		Article-No. 0584.053-071
Maintenance and Repair BXP 6401-X-(XX)		Article-No. 0584.061-071
Data Transfer Interface Protocol BXP 640X-XX-(XX)		Article-No. 0590.258-071
Installation and Operation BE6400-01-(XX)		Article-No. 0594.547-071

**BECKER**  
AVIONIC SYSTEMS  
INSTALLATION AND OPERATION  
BXP 6401-X-(XX)

BLANK

**BECKER**  
AVIONIC SYSTEMS  
INSTALLATION AND OPERATION  
BXP 6401-X-(XX)  
TABLE OF CONTENTS

INSTALLATION		Page
1.	General	2-1
2.	Inspection before installation	2-1
3.	Mechanical installation	2-1
4.	Aircraft wiring	2-1
5.	Installing the transponder antenna 1A032	2-4
6.	Programming of the Address Module	2-5
7.	Avionics data transfer	2-5
8.	Settings after installation	2-5
9.	Checking after installation	2-7
Fig. 2-1	Installation dimensions BXP 6401-X-(XX)	2-8
Fig. 2-2	Installation dimensions 1A032	2-9
Fig. 2-3	Proposal for aircraft wiring BXP 6401-X-(XX)	2-10
Fig. 2-4	RS-232 serial encoding altimeter connection	2-11

**BECKER**  
AVIONIC SYSTEMS  
INSTALLATION AND OPERATION  
BXP 6401-X-(XX)

BLANK

**BECKER**  
AVIONIC SYSTEMS  
INSTALLATION AND OPERATION  
BXP 6401-X-(XX)

INSTALLATION

1. General

Installation of the transponder BXP 6401-X-(XX) is depending on the aircraft type and its classification as well as requirements. Therefore, only general information can be provided in this section.

2. Inspection before installation

Before the transponder is installed on an aircraft, a visual inspection for possible transport damages shall be done.

Please look for the following defects:

- (1) Dirt, dents, scratches, corrosion, broken fastening elements on housing and housing parts.
- (2) Dirt and scratches on nameplate, front plate and inscriptions.
- (3) Dirt, bent or broken pins, cracked insert of unit connector and antenna socket.
- (4) Dirt, stiffness and mechanical damage to the pushbuttons, rotary switches and LC display.
- (5) Missing screws.

3. Mechanical installation

The transponder is designed for installation in the instrument panel of an aircraft. It is constructed for mounting behind the panel. The circular cut out and the mounting holes are to be drilled in accordance with the small instrument size. The mounting place shall be at least 30 cm from the magnetic aircraft compass, to avoid any interference to the magnetic compass by the transponder.

The necessary dimensions are given in Fig. 2-1. Attachment is by means of four screws M3x12, which are included in the delivery.

Blind Encoder installation:

For installation of the Becker Blind Encoder BE6400 the corresponding manual (Article- No. 0594.547-071) has to be noticed. The Blind Encoder BE6400 is intended to be connected to the J8 unit connector of the transponder and can be used only in installations that do not require connection of other equipment utilizing ADLP interface of the transponder. The Blind Encoder is direct connected to the transponder, without any interwiring.

4. Aircraft wiring

- A. The aircraft wiring of the transponder is shown in Fig. 2-3.

CAUTION :

For installations in a more severe electromagnetic environment use shielded cable connectors and a common shielding for the transponder interwiring.

**BECKER**  
 AVIONIC SYSTEMS  
 INSTALLATION AND OPERATION  
 BXP 6401-X-(XX)

B. RF connector

The unit RF connector is of the TNC female type. The antenna cable shall be of low-loss 50  $\Omega$  cable, at least RG 58C/U or better RG 223/U type.

Pin Name	Pin Description	Source	Destination	Recommended cable type
Antenna	50 $\Omega$ TNC antenna connector, female	bi-directional to the antenna	bi-directional to the antenna	RG58C/U or RG223/U

C. Pin connections of the unit connector P9

The unit connector type is D-SUB 25-pole male.

Pin	Pin Name	Pin Description	Source	Destination	Recommended cable type
1 2 3	A1 A2 A4	Altitude A1 Altitude A2 Altitude A4	Encoding altimeter (parallel interface)	BXP 6401-X-(XX)	3xAWG24
4	IDENT_N	Ident button, ext.	External Ident button	BXP 6401-X-(XX)	AWG26
5	EXT. SUPPRESSION	Aircraft suppression system	bi-directional	bi-directional	Coaxial cable
6	SWITCHED POWER OUT	Switched supply voltage I max = 1 A	BXP 6401-X-(XX)	Encoding altimeter	
7	REPLY OUT	Output for ext. reply lamp, lamp to be connected to positive illumination voltage	BXP 6401-X-(XX)	Reply lamp	AWG26
8 9	Not connected	RS-422 RX- RS-422 RX+ RS-422 data interface	Remote control	Remote control	
10	Illumination A	Illumination control	Illum. voltage	BXP 6401-X-(XX)	AWG24
11 12	SUPP	Supply voltage input, external 5 A fuse for current protection	DC supply voltage source 10 to 33 V	BXP 6401-X-(XX)	2xAWG20
13	GND	DC supply Ground, additionally connected to Pin 25	DC supply voltage Ground	BXP 6401-X-(XX)	AWG20
14 15 16 17 18 19 20	B1 B2 B4 C1 C2 C4 D4	Altitude B1 Altitude B2 Altitude B4 Altitude C1 Altitude C2 Altitude C4 Altitude D4	Encoding altimeter (parallel interface)	BXP 6401-X-(XX)	7xAWG24
21 22	Not connected	RS-422 TX- RS-422 TX+ RS-422 data interface	Remote control	Remote control	
23	Illumination B	Illumination GND	Illum. ground	BXP 6401-X-(XX)	AWG22
24	Not connected				
25	GND	Ground, additionally connected to Pin 13	DC supply voltage ground	BXP6401-X-(XX)	AWG20



**BECKER**  
 AVIONIC SYSTEMS  
 INSTALLATION AND OPERATION  
 BXP 6401-X-(XX)

D. Pin connections of the unit connector J8

The unit connector type is D-SUB 25-pole female.

Pin	Pin Name	Pin Description	Source	Destination	Recommended cable type
1	Not connected	Reserved for protocol selection			
2	Not connected	Reserved for GPIN1			
3	GND	Ground connection			
4	BSUPP	Supply for BE6400*	BXP 6401-X-(XX)	BE6400	
5	Not connected				
6	Not connected	Reserved for GPSRX-			
7	Not connected	Reserved for GPSRX+			
8	Not connected	Reserved for hijack mode (HI)			
9	Not connected	Reserved for hijack mode (HO)			
10	Not connected	Reserved for SQ			
11	GND SWITCH	"Weighth on wheel" sensor	Aircraft	BXP 6401-X-(XX)	AWG26
12	ALTS-	RS-422** data interface	Serial encoding altimeter	BXP 6401-X-(XX)	AWG 26 shielded
13	ALTS+				
14	TISRX-	RS-422 data interface	Avionics Data Link Processor	BXP 6401-X-(XX)	2xAWG26 twisted pair, shielded all together
15	TISRX+				
16	Not connected				
17	TISTX-	RS-422 data interface	BXP 6401-X-(XX)	Avionics Data Link Processor	2xAWG26 twisted pair, shielded all together
18	TISTX+				
19	Not connected				
20	Not connected				
21	GND	Ground			
22	Not connected				
23	Not connected				
24	Not connected				
25	Not connected				

\* **NOTE:** Do not connect if no BE6400 is used.

\*\* **NOTE:** See Fig. 2-4 for RS-232 serial encoding altimeter connection.

E. Pin connections of the unit connector J7

The unit connector type is subminiature 5-pole female.

Pin	Pin Name	Pin Description	Source	Destination
1	VCC	Power supply	BXP 6401-X-(XX)	AM 6400-1-(01)
2	I <sup>2</sup> C_CLK	Clock	AM 6400-1-(01)	BXP 6401-X-(XX)
3	Not connected	Reserved		
4	I <sup>2</sup> C_DAT	Data	AM 6400-1-(01)	BXP 6401-X-(XX)
5	GND	Power supply return	BXP 6401-X-(XX)	AM 6400-1-(01)

**BECKER**  
AVIONIC SYSTEMS  
INSTALLATION AND OPERATION  
BXP 6401-X-(XX)

F. DME suppression

If required, connect the suppression in/out of transponder to the corresponding pin of the DME unit or any relevant device.

G. External IDENT push-button

If this input (Pin 4 of unit connector P9) is briefly connected to GND (e.g. by an external push-button), the IDENT function (SPI) is started in the same way as when using the IDENT push-button on the front panel.

H. Ground switch

If required, connect an automatic ground switch (weight on wheel sensor) at Pin 11 of unit connector J8.

I. Illumination

For external illumination control connect the illumination voltage to pin 10 of P 9 and attach pin 23 to the illumination ground. Set the max. illumination voltage in the installation menu. For manual illumination control set dimming input to "none" in the installation menu. Set illumination intensity manually in the configuration menu.

5. Installing the transponder antenna 1A032

A. The transponder antenna has to be fitted to the bottom of the aircraft at a horizontal, flat location. This location should not be in the "shadow" of aircraft structure items. The highest range is achieved when the antenna is located at the lowest point of the aircraft fuselage.

B. The installation dimensions of the transponder antenna 1A032 is shown in Fig. 2-2.

CAUTION :

- The transponder antenna 1A032 is provided with a silicone rubber gasket which must also be interposed between the skin of the aircraft and the antenna.
- In aircraft having a wooden or plastic airframe an electric counterweight plate or panel must be located within the fuselage at the antenna location with minimum dimensions 40x40 cm (15.7x15.7 inch).

C. Antenna cable

RG-58C/U (0.9 dB/m) or RG-223/U (0.6 dB/m) can be used for the transponder. If the cable length is longer than 2 m between the unit and the antenna, the cable type RG- 223/U is recommended. The maximum cable length shouldn't be any more than 5 m. The complete loss of the antenna cable mustn't be greater than 3 dB.

**BECKER**  
AVIONIC SYSTEMS  
INSTALLATION AND OPERATION  
BXP 6401-X-(XX)

6. Programming of the Address Module

The 24-bit ICAO address once allocated by the local authority is stored for the assigned transponder in the Address Module AM 6400-1-(01).

The address module programmer kits AMP 6400-1 (parallel interface) and AMP 6400-2 (USB interface) are tools for reading and storing fixed aircraft data into the Address Module. This tools are for service and maintenance only.

The CD-ROM, which is part of the address module programmer kit, includes a description of the programming procedure. Insert the CD-ROM into a PC and follow the instructions. If autostart is disabled on your PC, you have to start "setup.exe" manually.

7. Avionics data transfer

- A. The BXP 6401-X-(XX) is a "data link transponder" according to RTCA DO-181C, respectively a "level 2" transponder according to Eurocae ED-73B. This stands for the capability to transfer data from the ground to a connected ADLP or a similar device and vice versa.
- B. The transponder transmits information as reply on a Ground Initiated Comm-B (GICB) request or by means of the extended squitter function. In both cases the valid information must be available in the GICB registers in the transponder.
- C. The transponder also transmits information by means of the Air Initiated Comm-B (AICB) function. In this case the information must be available in a special register in the transponder. The transponder announces the message and transmits it after authorisation from the ground station.
- D. In the other direction, the transponder is able to receive information within a Comm-A format from the ground station, which is then buffered and transferred to the connected device.
- E. In the BXP 6401-X-(XX) a "storage design" is implemented for uplink- as well as for downlink messages. This means that all information that might be transferred from the transponder is buffered inside the transponder first.
- F. The buffers can be accessed from an ADLP or a similar device via the interface on the rear connector J8. The interface is marked with "TISR X" and "TIST X" in the aircraft wiring diagram (see Fig. 2-3).
- G. The related protocol is specified in the attachment document "Data Transfer Interface Protocol BXP 640X-XX-(XX)". This manual is available at the Becker Product Support under the Article-No. 0590.258-071.

8. Settings after installation

Installation mode is available from SBY mode only. To get into installation mode press button SEL (G, see Fig. 3-1), turn with rotary encoder (B) until "INS" appears in the bottom line of the display. Select by pressing push-button (C). The installation setup is protected by password "6435". Enter password and press store button (F). See table on the next page.

**BECKER**  
 AVIONIC SYSTEMS  
 INSTALLATION AND OPERATION  
 BXP 6401-X-(XX)

Select with button (C)	Select with rotary encoder (B)		Store button (F)
ALTM SELECT	GARMIN / TRIMBLE NORTHSTAR UPS AT (BECKER BE6400) LORAN MAGELLAN SHADIN ARNAV GILHAM / PARALLEL	default	store store store store store store store
DIMMING INPUT	None (set illumination intensity manually in the configuration menu)  +5V DC +14V DC +28V DC	default	store  store store store
SQUITTER	Short ACQ SQU *	default on	off/on
REPLY RATE LIMIT	RPL RATE LMT 500-1200 replies/sec. in Mode A/C (setting in steps of 50)		store
SPECIALS	DATA LINK ** DEFAULT CONFIG *** ALT HIGH RESOL		store store store
Error Latch	LOW VOLT HIGH TEMP ANTENNA RF POWER DME ERR SQRT ERR CORE EE RECEIVER FIX DATA ALTIMETER DATA LINK Clear latch		view only view only view only view only view only view only view only view only view only view only view only store

\* Transponders equipped for extended squitter operation should have a means to disable acquisition squitters to facilitate the suppression of acquisition squitters when all TCAS units have been converted to receive extended squitter.

\*\* Shall be disabled if no ADLP or similar device is connected.

\*\*\* Default config.: Dimming input → none  
 Brightness → 50%  
 Altitude displayed in ALT mode  
 AI in SBY  
 AI in ON  
 Illumin. characteristics → max. range  
 Code → 0000  
 VFR → 0000  
 Flight number → eight blanks  
 Flight number → not active

NOTE: If no type is available, this field indicates nothing.

**BECKER**  
AVIONIC SYSTEMS  
INSTALLATION AND OPERATION  
BXP 6401-X-(XX)

9. Checking after installation

A. General

After the installation, check the transponder to ensure satisfactory operation of the unit.

B. Pre-flight check using selftest

Switch-on test:

Switch the transponder operating mode switch from OFF to SBY. A power-on built-in test (PBIT) then follows automatically for 1 second. During the test "WAIT" is indicated. If the test was successful, the unit switches then to the mode set on the mode switch.

Test triggered (IBIT):

Press the SEL button and STO button at the same time in mode ON or ALT. A test of all available test routines then follows for 1 second. During the test, "IBIT" is indicated on the display. If the IBIT was successful, the transponder switches immediately into the normal operating mode.

In case of a fault appears the report "FAILURE" in the display. Switch OFF the transponder at the fault indication.

C. Check of the address module

The installation company has to make sure that the corresponding address module AM 6400-1 is installed with the transponder and that the address module is programmed correctly. It is recommended to connect the address module with the aircraft tightly.

D. Test and adjustment of transmit frequency

Set code 0000 on the transponder and mode A interrogation on the ramp test set. Check transmit frequency by means of the ramp test set. Transmit frequency must be  $1090 \pm 1$  MHz. If out of range send the transponder to authorised service.

E. Check of the transmit power

After installation of equipment and antenna the transmit power has to be checked at the antenna end of the feeder line:

Requirement:  $\geq 125$  W (21 dBW) at class 1 transponder  
 $\geq 70$  W (18.5 dBW) at class 2 transponder

WARNING:

Radiation risk: A safe distance to the installed antenna must be ensured by corresponding installation measures around human body damage (e.g. at the eyes) and / or avoid the inflammation of combustible materials by radiated energy.

**BECKER**  
 AVIONIC SYSTEMS  
 INSTALLATION AND OPERATION  
 BXP 6401-X-(XX)

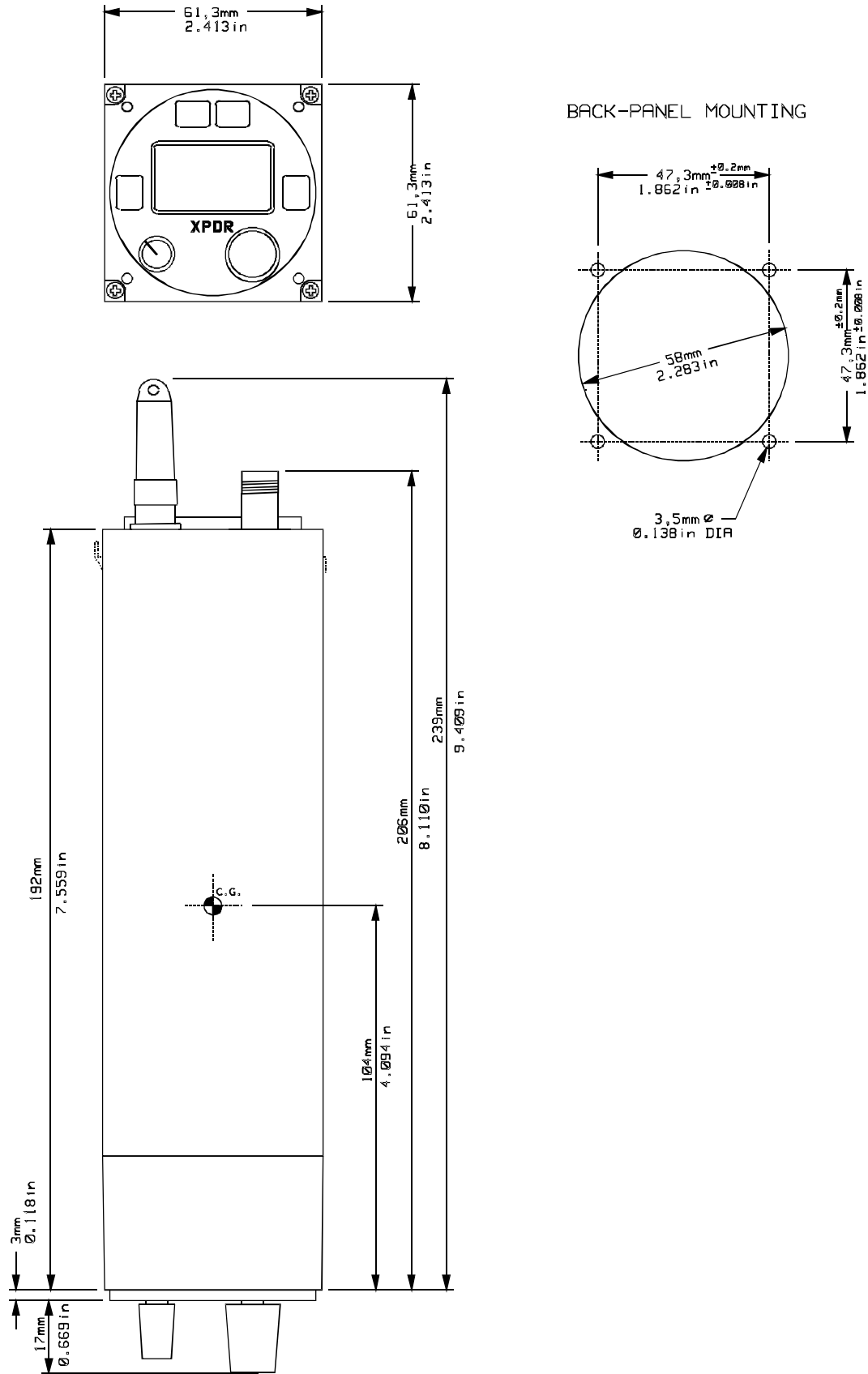

Fig. 2-1 Installation dimensions BXP 6401-X-(XX)

**BECKER**  
 AVIONIC SYSTEMS  
 INSTALLATION AND OPERATION  
 BXP 6401-X-(XX)

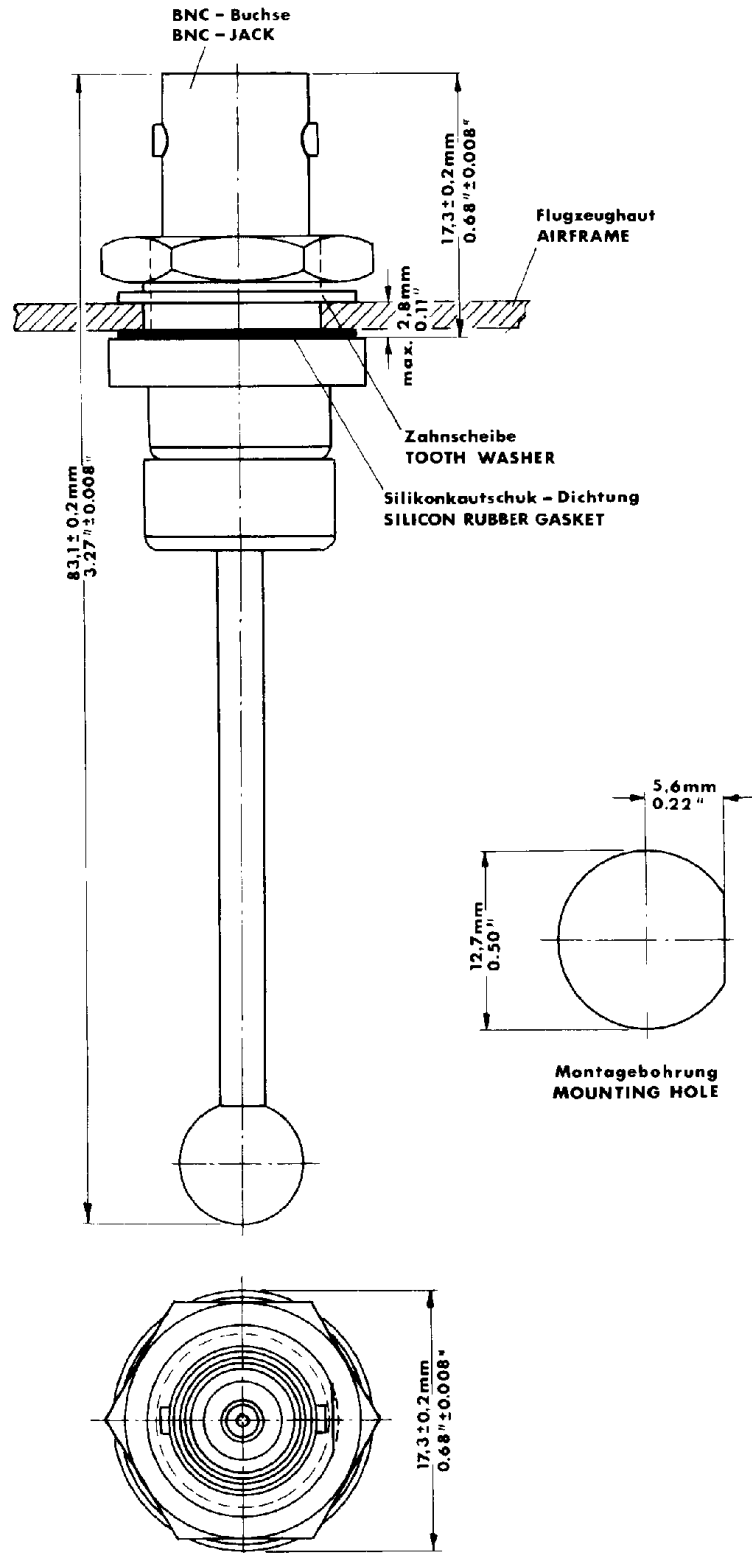

Fig. 2-2 Installation dimensions 1A032

# BECKER AVIONIC SYSTEMS

## INSTALLATION AND OPERATION

### BXP 6401-X-(XX)

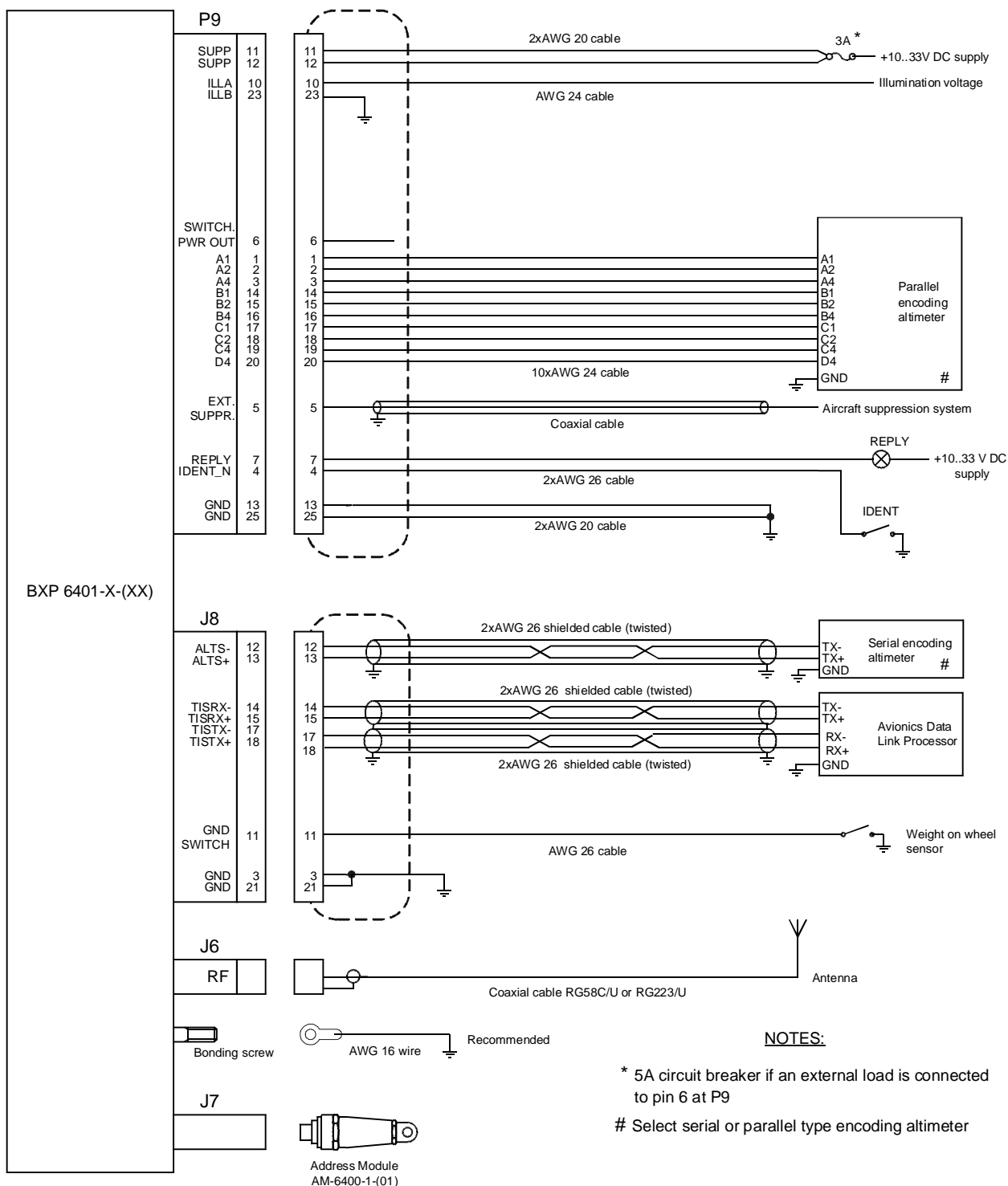

Fig. 2-3 Proposal for aircraft wiring BXP 6401-X-(XX)



**BECKER**  
AVIONIC SYSTEMS  
INSTALLATION AND OPERATION  
BXP 6401-X-(XX)

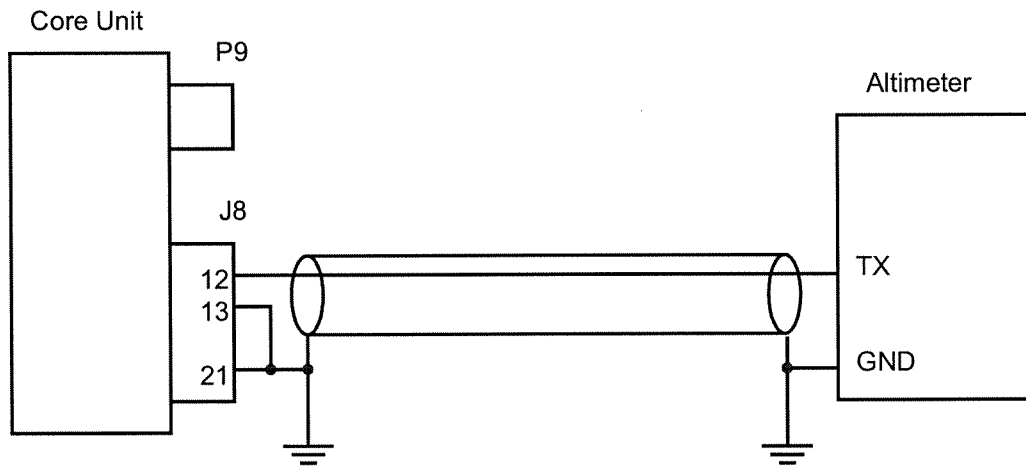

Fig. 2-4 RS-232 serial encoding altimeter connection

**BECKER**  
AVIONIC SYSTEMS  
INSTALLATION AND OPERATION  
BXP 6401-X-(XX)

BLANK

**BECKER**  
AVIONIC SYSTEMS  
INSTALLATION AND OPERATION  
BXP 6401-X-(XX)  
TABLE OF CONTENTS

OPERATION	Page
1. Controls and indicators	3-1
2. Function of controls and indicators	3-1
3. Operating instructions	3-2
A. Switching on the unit (pre-flight check)	3-2
B. Start-up	3-3
C. CODE display	3-3
D. Aircraft identification / Flight number	3-3
E. Flight level	3-4
F. Selftests of the unit (BITs)	3-4
G. Selection mode	3-5
G.1 Aircraft Identification (AI or FN)	3-6
G.2 VFR code setting	3-7
H. Flight operation in Mode A/C/S (reply and altitude code)	3-8
I. VFR code activation	3-9
J. Internal and external Ident	3-9
K. Special condings for air emergencies	3-9
L. Configuration mode	3-10
Fig. 3-1 Front view of the BXP 6401-X-(XX)	3-1
Fig. 3-2 Start-up indication	3-3
Fig. 3-3 AID indication	3-3
Fig. 3-4 FN indication	3-3
Fig. 3-5 Flight level indication	3-4
Fig. 3-6 Error indication and Warning indication	3-5

**BECKER**  
AVIONIC SYSTEMS  
INSTALLATION AND OPERATION  
BXP 6401-X-(XX)

BLANK

**BECKER**  
 AVIONIC SYSTEMS  
 INSTALLATION AND OPERATION  
 BXP 6401-X-(XX)

OPERATION

1. Controls and indicators

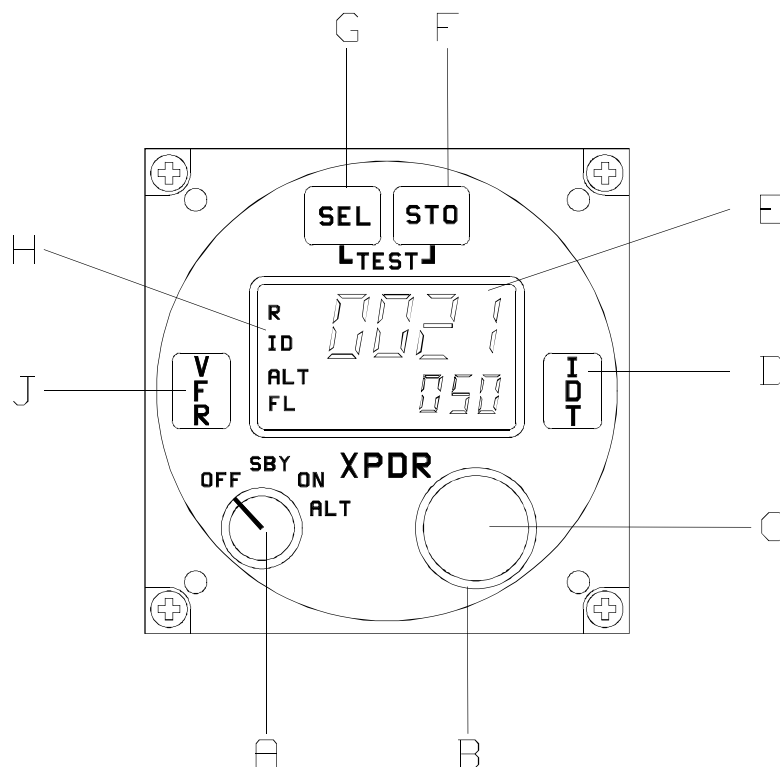

Fig. 3-1 Front view of the BXP 6401-X-(XX)

2. Function of controls and indicators

Ref. to Fig. 3-1	Controls and Indicators	Description	Function
A	Mode selector	Rotary switch with 4 positions	<p>OFF position: Transponder is switched off</p> <p>SBY position: Standby mode is switched on</p> <p>ON position: Mode A/S is switched on. Transmission of altitude information is suppressed.</p> <p>ALT position: Mode A/C/S is switched on and the altitude information is transmitted.</p>
B	Rotary switch	Rotary optical encoder (rotary mode of C)	Rotary switch to change settings (16 steps per turn)

**BECKER**  
 AVIONIC SYSTEMS  
 INSTALLATION AND OPERATION  
 BXP 6401-X-(XX)

Ref. to Fig. 3-1	Controls and indicators	Description	Function
C	Button	Push-button (mode of B)	Push to jump from digit to digit for settings or from one menu to the next; generally used as an enter key
D	IDT	Push-button	Activates the Special Identifier (SPI) in addition to the reply code for approx. 18 seconds; during this time "ID" appears in the LC display
E	Display, part 1	2-line LCD display	Displays the following informations: - code indication in the top row - flight level in the bottom row - various informations in the bottom row - additional indicators on the left side (see Ref. H)
F	STO	Push-button	Stores the selected values to the settings
G	SEL	Push-button	Opens and selects the menu
H	Display, part 2	LCD indicators	Displays additional indicators, (R for reply, ID for Ident, ALT for XPDR ALT mode or ON for XPDR ON mode, FL for flight level)
J	VFR	Push-button	Activates VFR code in the upper row of the display

3. Operating instructions

A. Switching on the unit (pre-flight check)

- (1) Check that the circuit breaker is set and switch on the aircraft power supply.

**CAUTION:** Do not switch on the transponder before the aircraft engines are started. Switch off the transponder before the engines are shut down.

- (2) Using mode switch (A), switch the transponder from OFF to SBY. A Power-on Built-In Test (PBIT) then follows automatically for 1 second. Start-up see also section B.

**BECKER**  
AVIONIC SYSTEMS  
INSTALLATION AND OPERATION  
BXP 6401-X-(XX)

B. Start-up

On power-up, the device starts. The software initiates circuits and performs PBIT. During that time the display looks as follows.



Fig. 3-2 Start-up indication

After the PBIT has elapsed and no error-message is shown in the display, the transponder switches to the mode set by the mode switch (A).

C. CODE display

Transponder's code is displayed in the top line using high readability font, at all times in modes SBY, ON, ALT.

D. Aircraft identification / Flight number

Depending on the configuration settings, the Aircraft Identification (AI) or Flight Number (FN) is displayed in the bottom line as follows:



Fig. 3-3 AI indication



Fig. 3-4 FN indication

**BECKER**  
AVIONIC SYSTEMS  
INSTALLATION AND OPERATION  
BXP 6401-X-(XX)

E. Flight level

Flight level is displayed in ALT mode in the bottom line of the display (altitude = FL x 100 in ft):

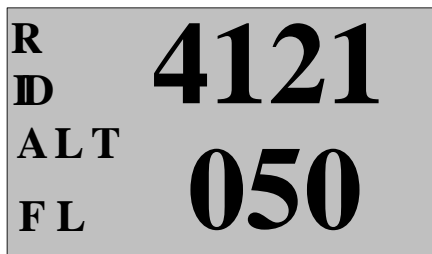

Fig. 3-5 Flight level indication

F. Selftests of the unit (BITs)

The following different tests are integrated in the transponder or can be triggered at the transponder:

- (1) The IBIT (Initiated Built-in Test) can be activated in any mode (excluding the configuration mode) with the push of (F) and (G) at the same time. The action starts with the leading edge of the second pushed button.

The IBIT works as follows in all modes:

The test starts with all available test routines including the transmitter test routine. During the test, "IBIT" is indicated on the display. The test takes not longer than 1 second. If the IBIT was successful, the XPDR switches immediately into the normal operating mode. During the IBIT any action from other switches is not recognized.

Negative results of the IBIT are indicated on the display with "FAILURE". The transponder may be not switched into ON or ALT mode if any failure was found.

- (2) The CBIT (Continuous Built-in Test) works as follows:

The continuous BIT acts as a kind of watchdog during operation. Negative results of the CBIT are indicated on the display with "FAILURE". In this case the transponder may be not switched into ON or ALT mode (display indication of operating mode set to SBY) if any failure was found.

- (3) The PBIT (Power-on Built-in Test) works as follows:

The XPDR has a power-on BIT after switching on. During the PBIT any actions from other switches are not accepted.

During the PBIT the XPDR is in the SBY mode but this is not indicated on the display. The operating mode indication on the display starts immediately after finalisation of the PBIT.



**BECKER**  
AVIONIC SYSTEMS  
INSTALLATION AND OPERATION  
BXP 6401-X-(XX)

Negative results are indicated on the display with "FAILURE". The transponder may be not switched into ON or ALT mode if any failure was found.

The PBIT takes not longer than 1 second. If the test was successful, the XPDR switches immediately into the normal operating mode.



Fig. 3-6 Error indication and Warning indication

G. Selection mode

Press SEL button (G) and rotate encoder (B) for selection. In selection mode additional information is displayed in the bottom line of the display. Some of the data are editable, some are read only:

VFR	4096 code presetting	editable; see section G.2
AI	Aircraft Identifier (Tail Number)	fixed; read only from address module (can be replaced by FN) If no valid AI is stored, "-----" is displayed.
FN	Flight Number or Company Call Sign	editable; see section G.1, can be replaced by AI (fixed) by selecting "AI DEF"
AA	Aircraft Address (24-bit ICAO)	fixed; read only from address module (unique number for each aircraft)
MA	Maximum Airspeed	fixed; read only from address module
AT	Aircraft Type	fixed; read only from address module
CFG	Configuration	available in SBY mode only, see section L
INS	Installation setup	available in SBY mode only; protected by password, see chapter 2, section 8

**BECKER**  
AVIONIC SYSTEMS  
INSTALLATION AND OPERATION  
BXP 6401-X-(XX)

G.1 Aircraft Identification (AI or FN)

With flight plan:                      The definition out of the flight plan:  
e.g. Flight Number or Company Call Sign

Without flight plan (VFR):        Tail Number (Call Sign)

The indication of AI in the bottom line of the display is in mode SBY and ON only if selected in configuration menu. The Aircraft Identifier (fixed) is available in any mode after pressing SEL button (G) and turning the rotary encoder (B). The default value for AI is the Tail Number of the aircraft and is stored in the Address Module.

If a flight plan exists, it has to be checked, which AI has to be used. If a Flight Number is assigned it has to be entered. If a Company Call Sign is mentioned, this has to be entered. To enter it see below. It will be stored in the EEPROM of the control head. In this case the indication on the display changes to FN (Flight Number). If the Call Sign (Tail Number) is mentioned, no change, as it is the default setting from the Address Module.

Setting the flight number:

- (1) Press SEL button (G) to enter the select mode.
- (2) Rotate (B) until AI is displayed.
- (3) Push (C) to switch to FN. The cursor is set on the first character.
- (4) Rotate (B) to change this character.
- (5) Push (C) to set the cursor to the next character.
- (6) Repeat steps 4 and 5 until the flight number is entered.
- (7) If the flight number consists of less than 7 characters, put a space at the end to fill the remaining characters with spaces.
- (8) Store the changes with STO button (F). For leaving the setting procedure without storing, push the SEL button (G).

NOTE:

Aircraft Identifier / Flight Number consists of max. 7 characters (on the left-hand side oriented). No dashes or spaces shall be included. If the FN consists of less than 7 characters, the remaining characters on the right side shall be filled with spaces.

Switching back to default AI:

- (1) Press SEL button (G) to enter the select mode.
- (2) Rotate (B) to the indication FN=XXXXXXXX.
- (3) First push on (C) indicates "FN=AI DEF" (inverted).
- (4) Can be set to AI=DEF with STO button (F).

**BECKER**  
AVIONIC SYSTEMS  
INSTALLATION AND OPERATION  
BXP 6401-X-(XX)

Changing the flight number:

- (1) Press SEL button (G).
- (2) Rotate (B) until FN is displayed.
- (3) Push (C) twice to enter the FN editing mode.
- (4) Change the FN as described above.

## G.2 VFR code presetting

Press the SEL button (G) to get into configuration mode (selection is indicated in the left bottom corner of the display under the operating mode indication).

- (1) Rotate (B) to the indication VFR=XXXX.
- (2) First push to button (C) ⇒ left digit of the code is inverted.
- (3) Now the digit can be changed with (B).
- (4) Second push to button (C) ⇒ next left digit of the code is inverted.
- (5) The next digit can be changed with (B)
- (6) and the same for next digits.
- (7) Fifth push to button (C) ⇒ again first digit is inverted.
- (8) Changes can be stored with STO button (F) at any time, inversion stops in this case.
- (9) A VFR code that was preset in this way can be activated as described in chapter I.
- (10) A timeout for inversion (10 sec) is introduced if no action happens. Nothing stored, as long as (F) is not pressed.

### NOTE:

It is possible to leave the setting procedure with SEL button (G) at any time and normal mode is available then. Indication SEL on the display changes back to mode indication. If STO button (F) was not used, no change has been stored.

**BECKER**  
AVIONIC SYSTEMS  
INSTALLATION AND OPERATION  
BXP 6401-X-(XX)

H. Flight operation in Mode A/C/S (reply code and altitude code)

- (1) When ATC requests the transmission “squawk”, switch the transponder to ALT using mode switch (A).

NOTES: This only makes sense if the transponder is connected to a coding altimeter. If not, tell ATC that you do not have mode C (“mode charlie not available”).

In exceptions the altitude has to be turned off, i.e. switch the transponder to ON using mode switch (A).

- (2) The transponder replies using the selected Code and in response to mode C interrogation it transmits the altitude of the aircraft to ATC. A “R” on the left next to the Code on the display signals the transponder replies.

NOTE : Switch the transponder to Stand-by (SBY), if the Code has to be changed. Otherwise it could happen that a Code with a special meaning (see chapter K, e.g. hijack) will be transmitted and unwanted actions could take place.

- (3) After a “squawk ident” request from ATC, press Ident button IDT (D) briefly. This transmits an additional special pulse (SPI) for approx. 18 seconds, which enables the aircraft to be clearly identified on the radar screen of the controller. “ID” appears on the left side in the LC display during this time.
- (4) In a normal installation the blind encoder is only powered if the transponder is not switched OFF (at least SBY).

A blind encoder needs a warm-up time (sometimes several minutes).

Therefore, although the solid state transponder needs no warm-up time, turn the transponder to SBY immediately after starting the engine.

**BECKER**  
AVIONIC SYSTEMS  
INSTALLATION AND OPERATION  
BXP 6401-X-(XX)

I. VFR code activation

- (1) Press the VFR push-button (J). The preselected code is then displayed. After 3 seconds, the displayed code gets active and overwrites the previously-set reply code.
- (2) Pressing push-button (J) again within 3 seconds reactivates the previously-set reply code.

NOTE :

When the unit is delivered, the VFR button is not assigned a code. This means that if this button is pressed for 0.5 seconds, "----" is shown in the code display and the transponder then switches back to the previously-active code.

J. Internal and external Ident

The special identifier pulse (SPI) can be triggered by pressing "IDT" button on the control panel or from external input located on the transponder.

If special identifier pulse has been triggered, then "IDT" is displayed on the display as long as SPI is active.

K. Special codings for air emergencies

- (1) Special codings, which depend on the type of incident, are stipulated for certain air emergencies:
  - 7500            Hijacking
  - 7600            Loss of communications
  - 7700            Emergency on board which constitutes an immediate danger to the aircraft
- (2) The code evaluation devices of the radar systems automatically alarm the controllers at the radar screens immediately if one of these special codes is received.

**BECKER**  
 AVIONIC SYSTEMS  
 INSTALLATION AND OPERATION  
 BXP 6401-X-(XX)

L. Configuration mode

The configuration mode is available from SBY mode only. To get into configuration mode press button SEL (G), turn rotary encoder (B) until "CFG" appears in the bottom row of the display. Available options are defined in the following table.

Select with push-button (C)	Select with rotary switch (B)		Store button (F)
BRIGHTNESS  (only if dimming input is set to "none" in installation menu)	0 %		store
	...		store
	50%	default	store
	...		store
	100 %		store
ILLUM CURVE  (only if external illumination control is set in the installation menu)	Characteristics		store to change
VIEW CONFIG	AI IN SBY	default	ON
			OFF
	AI IN ON	default	ON
			OFF
	FL IN ALT	default	ON
			OFF
DEVICE INFO	CU VER		view only
	CORE VER		view only
	FPGA VER		view only
	DEV TYPE		view only
	SERIAL NB		not supported

NOTE: If no type is available, this field indicates nothing.